

NAME: LED Retrofit Kits

P/N: 33150202

Advantage:

- UL DLC certificate
- PHILIPS Chip, SUNON fan
- high CRI
- Mean Well IP65 driver,
Input voltage 100-277VAC
- No UV or IR in the beam
- Easy to install and operate
- Energy saving, long service life
- Light is soft and uniform, safe to eyes
- Instant start, NO flickering, NO humming
- Green and eco-friendly without mercury.

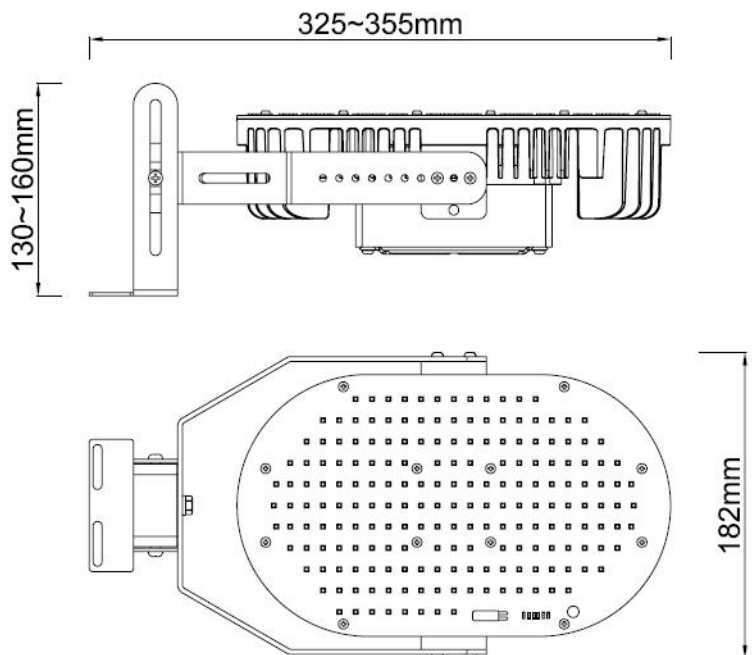

Application:

- ◆ Outdoor Pole/Arm-mounted Area and Roadway Luminaires.

Product Specifications

Product name	LED Retrofit Kits
Part No	33150202
Light Type	Retrofit Kits
Dimension	(325-355) *182* (130-160) mm

Technical Characteristic

Color temperature	4000K	4500K	5000K	5700K
CRI	>80			
Lumen	17000-20000LM			
Input Power	150W			
Viewing Angle	120 Degree			
Input Voltage	100-277VAC		50/60Hz	
Driver model	CLG-150-48A(Mean Well Driver)			
PFC	>0.9			
Equivalent	1200W incandescent / 350W CFL			
Waterproof Rating	IP40			

Materials

LED Brand	PHILIPS
LED Type	3030, 1.5W
LED QTY	175 PCS
Housing	Aluminum
Housing color	Gray

Others

Operating Temperature	-20℃ TO 45℃
Operating Humidity	20%- 90% RH
Storage Temperature	-30℃ TO 80℃
Storage Humidity	10%- 95%
Application	Outdoor Pole/Arm-mounted Area and Roadway Luminaires
Safety Certification	UL, DLC
Warranty Time	5 Years

Package

Lamps Net Weight: 3.7 Kg/pcs

	Size	Qty/Carton	Weight/Carton
Inner box	41*29*16 CM	1	4.5 kg
Outer box	65*42*31 CM	4	19 kg

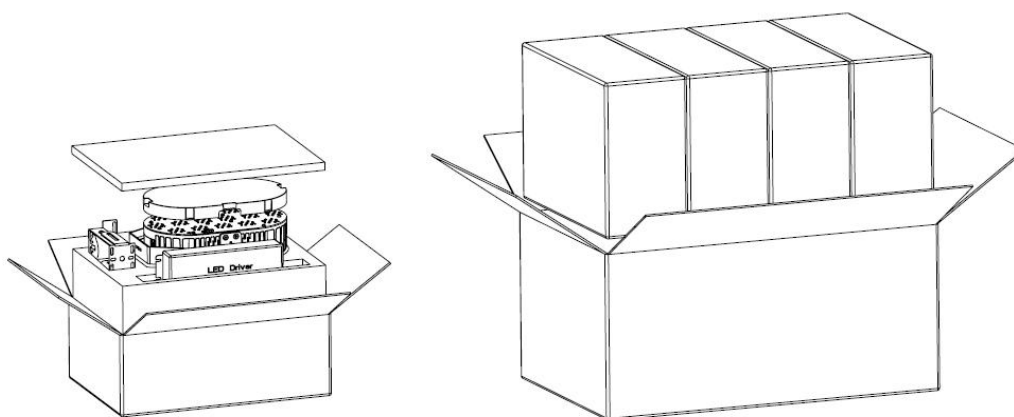

Notice For User

- ◆ Please turn off power before install or change assembly parts.
- ◆ The input voltage and lamps should be matched, after connecting the power line, Please make sure the wiring section is insulated.
- ◆ No-professionals, must not install and disassemble the lamps.

Trouble Shootings

Troubles	Check points
Flickering of the light	Turn off the power and turn on again in 3 minutes. If same phenomena occur, then call agencies
Out of working	Please check the connection