

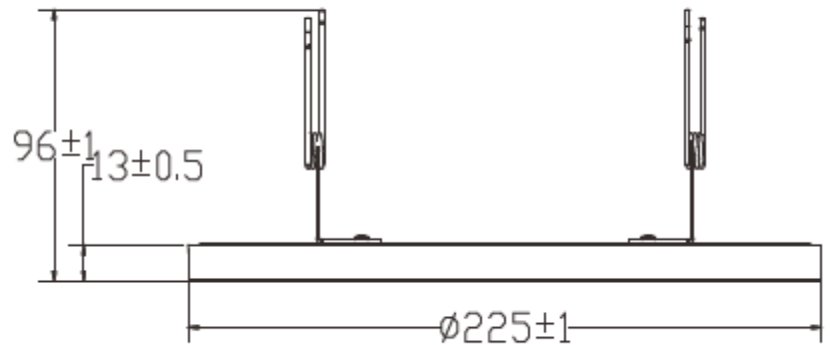

TECHNICAL DATA SHEET

NAME : LED Round Panel Light

P/N : KLBR18FDLXX8I



Advantage

- Easy installation to save labor cost.
- High lumen efficacy to save energy.
- DLC or Energy Star approved, rebate is available.
- 50000h long life time, 5 years warranty term.



Application

- Office, hotel, residential or commercial indoor luminaires.



Krut Systems LLC



PRODUCT SPECIFICATIONS	
Product name	LED Round Panel Light
Part No	KLBR18FDLXX8I
Light Type	Down Light
Dimension	ø225mm X H 13 mm (ø 8.8" X H 0.5")
TECHNICAL CHARACTERISTIC	
Color temperature	3000K, 4000K, 5000K
CRI	>80
Lumen	1530 LM
Input Power	18 W
Beam Angle	120 degree
Input Voltage	120V AC
Waterproof Rating	IP20
Dimmable	Yes, Triac
L70 Life span	>50000Hrs
OTHERS	
Operating Temperature	-20°C TO 40°C
Operating Humidity	20%- 90% RH
Storage Temperature	-30°C TO 80°C
Application	Indoor Light
Safety Certification	ETL, ES
Warranty Time	5 Years

XX means different color temperature as - 2K7-2700K, 3K-3000K, 4K-4000K, 4K5-4500K, 5K-5000K, 5K7-5700K



PACKAGE

20pcs/CTN Dimension: 18.7"L x 8.3"W x 9.4"H (475mmx210mmx240mm)

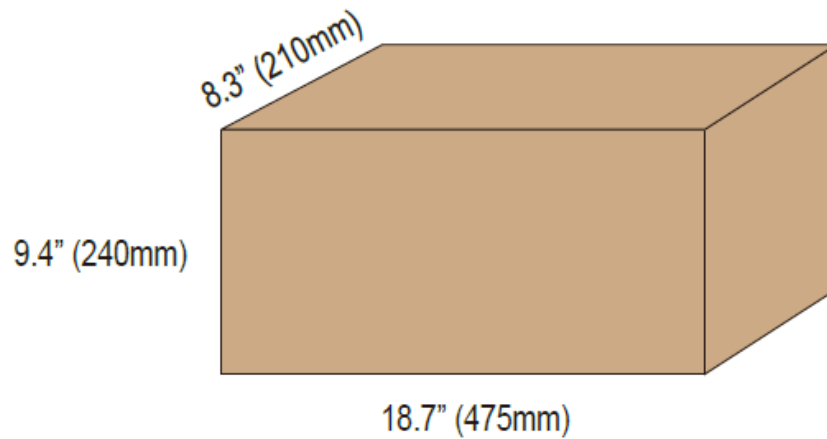

INSTALLATION

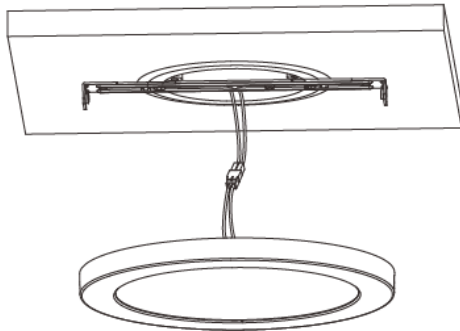

J-BOX Mount

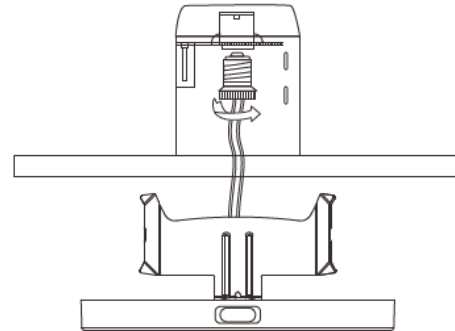

5" / 6" Retrofit