

## Package

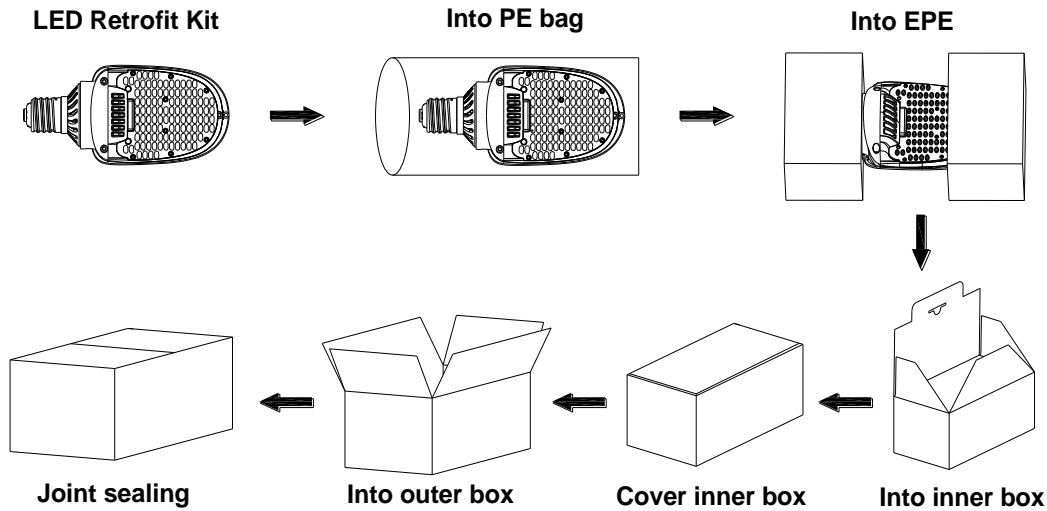

	Size	Qty/ Carton	Net Weight/ Carton	Gross Weight/ Carton
Inner box	340*160*110 MM	1 PC	1.31 KG	1.55 KG
Outer box	660*355*240 MM	8 PCS	10.5 KG	13.4 KG

## Notice For User

- Please turn off power before install or change assembly parts.
- The input voltage and lamps should be matched, after connecting the power line, please make sure the wiring section is insulated.
- Make sure to remove or bypass the ballast in the fixtures before install the lamps.
- Suitable for damp locations. Do not use with dimmers.
- Suitable for use in enclosed luminaires, min. lamp compartment dimensions: 440\*260\*260MM.
- No-professionals, must not install and disassemble the lamps.

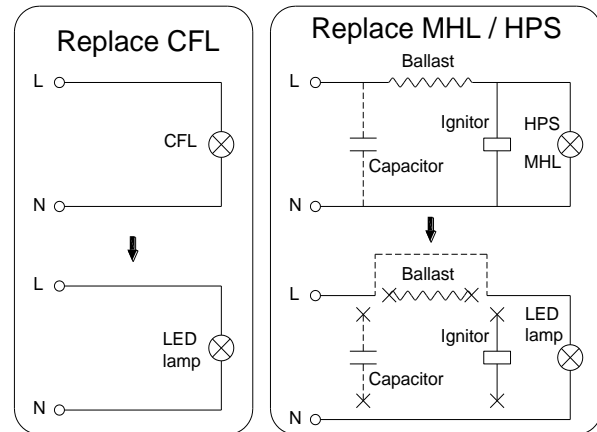

## Trouble Shootings

Troubles	Check points
Flickering of the lamps	Turn off the power and turn on again in 3 minutes. If same phenomena occur, then call agencies
Out of working	Please check the connection