

NAME: LED Corn Light

P/N: 1312530[2,3]

Note : The [2,3] in P/N stands for Lamp base type, "2" for E39 lamp base, "3" for EX39 lamp base.

Advantage

- UL DLC certificate.
- E39、EX39 lamp base.
- 360 degree lighting.
- IP64 Waterproof Rating.
- Big heat sink, NO fans.
- Internal driver, input voltage AC100-277V.
- Sealant pouring for whole driver and lamp plastic housing.
- New style and high efficient wide-range input.
- Long lifespan and good heat dissipation.
- Direct replacement for Metal Halide, easy Installation.
- Fits many different fixtures to replace traditional lamps.

Application

Replacement Lamps for Outdoor Pole/Arm-mounted Decorative Luminaires (Type B).

PRODUCT SPECIFICATIONS		
Product name	LED Corn Light	
Light Type	Corn Light	
Part No	13125302	13125303
Lamp Base	E39	EX39
Dimension	Φ146*271 MM	Φ146*274 MM
Technical Characteristic		
Cover	Clear	
Color temperature	3000K、3500K、4000K、4500K、5000K、5700K	
CRI	> 80	
Lumen-In Luminaires	12300-13300 LM	
Lumen Efficacy-In Luminaires	97-105 LM/W	
Input Power	125 W	
Viewing Angle	360 degree	
Input Voltage	AC100-277V 50/60Hz	
PF	>0.9	
Equivalent	200W CFL , 400W MHL/HPS/HID	
Waterproof Rating	IP64	
MATERIALS		
LED Type	SMD2835	
LED QTY	928 PCS	
Housing	PC+AL	
Housing color	White+Grey	
OTHERS		
Operating Temperature	-20°C TO 45°C	
Operating Humidity	20%-70% RH	
Storage Temperature	-30°C TO 80°C	
Storage Humidity	10%-75% RH	
Application	Indoor/Outdoor	
Safety Certification	UL, DLC	
Warranty Time	5 Years	

Package

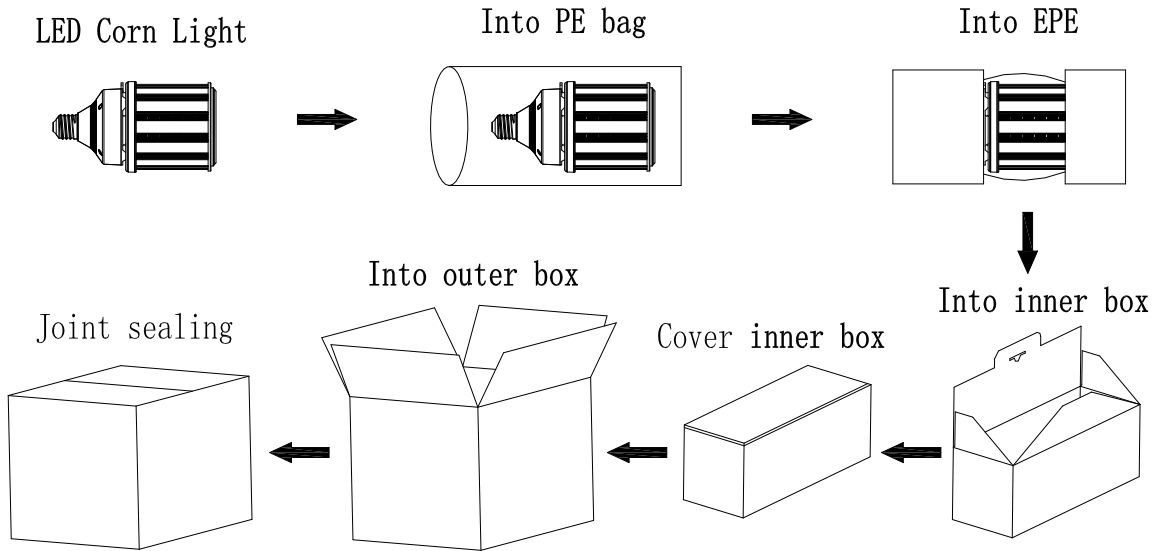

	Size	Qty/ Carton	Net Weight/ Carton	Gross Weight/ Carton
Inner box	310*165*165 MM	1 PC	1.58 KG	1.82 KG
Outer box	510*345*330 MM	6 PCS	9.5 KG	11.9 KG

Notice For User

- Please turn off power before install or change assembly parts.
- The input voltage and lamps should be matched, after connecting the power line, please make sure the wiring section is insulated.
- Make sure to remove or bypass the ballast in the fixtures before install the lamps.
- Suitable for damp locations. Do not use with dimmers.
- Suitable for use in enclosed luminaires, min. lamp compartment dimensions: 450*280*280MM.
- No-professionals, must not install and disassemble the lamps.

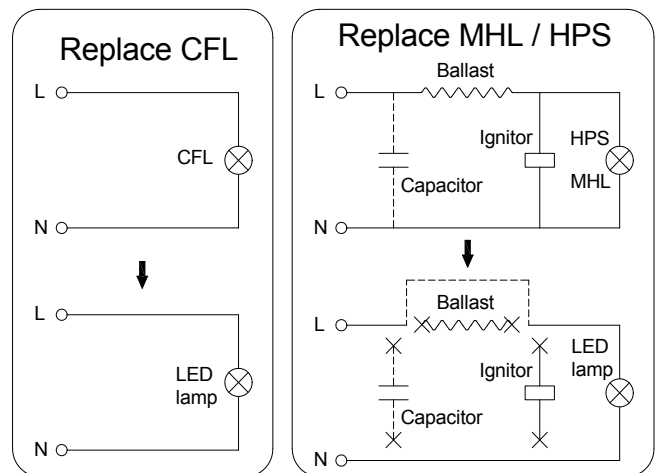

Trouble Shootings

Troubles	Check points
Flickering of the lamps	Turn off the power and turn on again in 3 minutes. If same phenomena occur, then call agencies.
Out of working	Please check the connection.